

STRATUS LIFT

Refined Capability



COMMERCIAL

[trustram.com](https://www.trustram.com)
1-800-563-4382





STANDARDIZED PERFORMANCE

The Commercial Stratus lift is the practical turnkey mobility solution for buildings up to two storeys and four intermediate stops. A standard format, constant pressure operation, the Commercial Stratus is available in three car sizes and travel distances, with a range of finishing options, offering flexibility and value that doesn't compromise performance.

The Stratus' standardized sizing eliminates complexity and cost and significantly reduces installation time, making it an ideal addition to both new builds and renovations alike. With its completely enclosed car, it affords riders the experience of an elevator at a fraction of the price.

[trustram.com](https://www.trustram.com)
1-800-563-4382



THE HIGHLIGHTS

IDEAL FOR:



Commercial Spaces



Indoor Use

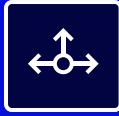

Multiple Entry/Exit

MAX CAPACITY:

800 LBS

MAX TRAVEL SPEED:

20 FT/MIN

MAX TRAVEL DISTANCE:

14 FT

ENTRANCE/EXIT POINTS:

**In-out same side,
Straight through,
or Adjacent**

MAX CAR SIZE:

W40" x L60"

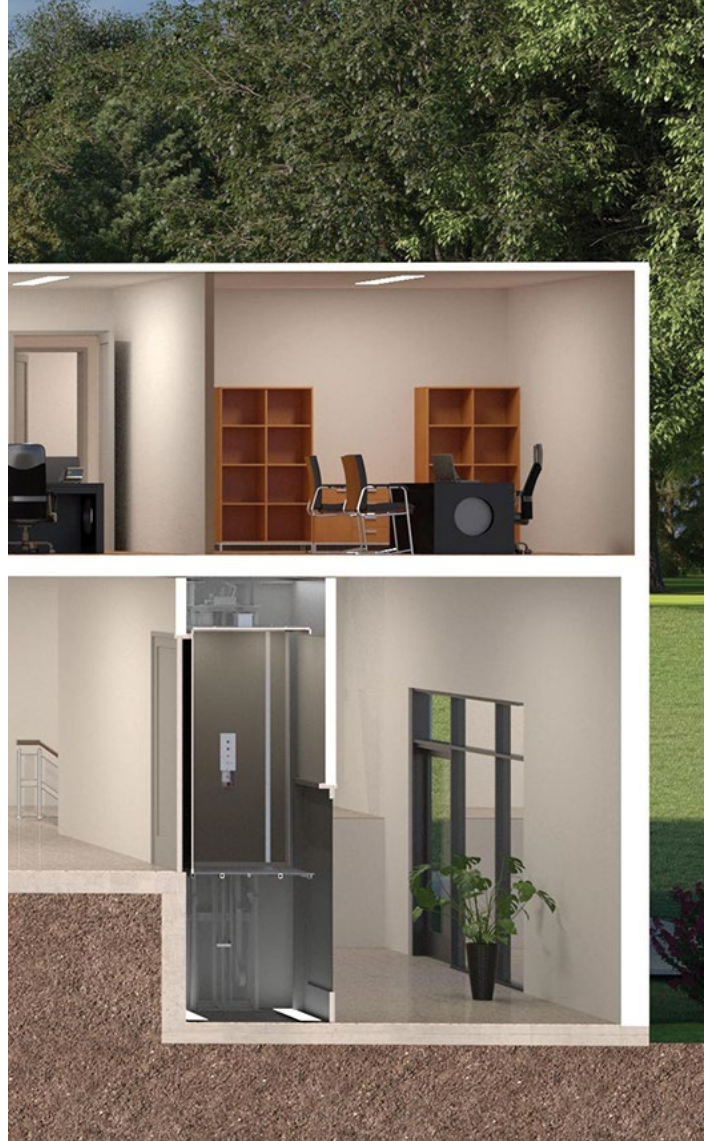

KEY FEATURES

Tailored Finishes

Choose from three standard car sizes and travel distances, in addition to multiple interior finishes and door styles to complement your space.

Constant Pressure Buttons

Give riders full control while in motion with constant pressure buttons and manual or automatic doors.

Economical Performance

The Commercial Stratus lift is 50% less expensive than our Traction LULA Elevator and as much as 80% less than a commercial passenger elevator.

Soft Start/Stop **RA**

Thoughtful engineering means every ride on a RAM product begins and ends with comfort in mind.

All-Electric Drive System **RA**

RAM's proven electric drive system is reliable, powerful and whisper-quiet. Plus, no hydraulic fluid = no harsh smells.

Machine-Room Less (MRL) Design **RA**

While other commercial lifts may need a separate room for essential machinery, every RAM product is compact and self-contained, saving you space, time and money.

Low Overhead Clearance **RA**

Smart space design delivers the most space-efficient MRL product on the market. All drive components mount directly to the top of the RAM rigid guiderail frame fitting into a standard 92" top-floor ceiling height.

No Pit Required **RA**

Choose a pitless build with a 2" ramp, ideal for existing spaces, or a 2" pit for flush access.



RA = RAM Advantage, an essential feature found in all of our products.

The Stratus Range

Pick from three standard car sizes and three travel heights to best meet your needs.

Some customization is also possible, as needed.

	Car Inside Dimensions			Shaft Dimensions	
	Width (W)	Depth (D)	Height (C)	Depth (SD)	Length (SL)
Small	36"	48"	84"	50.5"	53.5"
Medium	40"	54"	84"	54.5"	59.5"
Large	40"	60"	84"	54.5"	65.5"

Max Travel (T)	Min Overhead Clearance*	Tower Height (TH)
9'	92"	13'
11'	92"	15'
14'	92"	18'

* Overhead Clearance is measured from the floor of the top landing.
The travel for each size is infinitely adjustable up to the maximum travel height

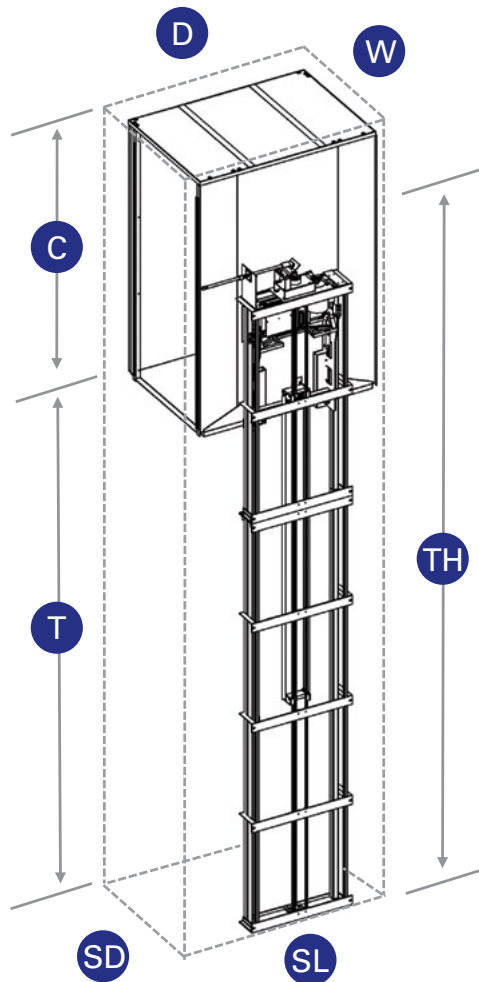



trustram.com
1-800-563-4382



LEADING-EDGE QUALITY AND DEPENDABILITY

Superior Reliability

Three tiers of emergency auxiliary power are available for every RAM product:

1. Emergency manual crank & battery backup for car lighting and controls (Standard)
2. Battery backup lowering will run the motor in the down direction during a power outage (Optional)
3. Full battery 40-cycle backup that will run the motor with full load for 40 cycles during a power outage (Optional)

Maintenance

Total cost of ownership is critical. By design, RAM has one of the lowest maintenance offerings that still ensures safe operation during the entire lifecycle. We know that low maintenance with a focus on safety is the key to peace of mind.



Power Requirements

220 VAC, 1PH, 20A MAIN Power

110 VAC, 1PH, 15A Shaft Lights & Plugs

Warranty

The RAM Commercial Stratus is covered by a 2 year warranty. Extended Warranties Available, Contact RAM for details.

Code Relevance

Designed to meet ADA, ASME A18.1/CSA B355 safety standards when properly equipped.

While RAM commercial lifts meet national standards, it is imperative to check State/Provincial and Local code requirements before installing to ensure compliance. All State/ Provincial and Local compliance is the responsibility of the purchaser. Some states may require fees for site preparation and permits.



trustram.com
1-800-563-4382

